



Transforming Industries  
with **AI Drones**,  
Drones as a Service  
& Quantum Computing

**INVESTOR PRESENTATION**

**January 2025**

NASDAQ: **ZENA** | FSE: **49Q**



# SAFE HARBOR STATEMENT

This presentation does not constitute an offer to sell or the solicitation of an offer to buy, nor shall there be any sale of the securities of ZenaTech, Inc. (the “Company”) in any jurisdiction in which such offer, solicitation or sale would be unlawful prior to registration or qualification under the securities laws of such jurisdiction. None of the securities of the Company have been and will not be registered under the United States Securities Act of 1933, as amended (the “US. Securities Act”), or any state securities laws and may not be offered or sold within the United States or to, or for the account or benefit of “US persons,” as such term is defined in regulations under the US securities act, unless an exemption from such registration is available.

This presentation does not constitute or form part of and should not be construed as, an offer to sell or issue or the solicitation of an offer to buy or subscribe for securities of the Company in any jurisdiction or an inducement to enter into investment activity. No part of this presentation, nor the fact of its distribution, should form the basis of, or be relied on in connection with, any contract or commitment or investment decision whatsoever. No securities commission or similar authority of the United States, Canada, or any other jurisdiction has reviewed or in any way passed upon this presentation or the merits of the securities described herein, and any representation to the contrary is an offence. This presentation does not contain all of the information that would normally appear in a prospectus or registration statement under applicable Canadian or United States securities laws. Readers should not construe the contents of this presentation as investment, legal, tax, regulatory, financial or accounting advice and are urged to consult with their own advisers in relation to such matters.

This document is not, and under no circumstances is to be construed as, an advertisement or a public offering of the securities of the Company in any jurisdiction. The Company does not make any representation or warranty (express or implied) as to the accuracy or completeness of the information in this presentation. Except as may be required by applicable law, the Company expressly disclaims any obligation to update any of the information contained herein or to inform readers of any matters of which it becomes aware that may affect any matter referred to in this presentation. Certain information in this presentation is based on management estimates. Such estimates have been made in good faith and represent the current beliefs of management. Management believes that such estimates are founded on reasonable grounds. However, by their nature, estimates may not be correct or complete. Accordingly, no representation or warranty (express or implied) is given that such estimates are correct or complete. Market data and certain industry data and forecasts included in this presentation were obtained from internal company surveys, market research, publicly available information, reports of governmental agencies and industry publications and surveys.

Where this presentation quotes any information or data from any third-party source, it should not be interpreted that the Company has adopted or endorsed such information or data as being accurate. The Company has not independently verified any of such information from third-party sources or any underlying assumptions. Accordingly, the Company makes no representation or warranty (express or implied) on the fairness, accuracy, completeness or correctness of any such third-party information.

Certain statements contained in this presentation, other than statements of fact that are independently verifiable at the date hereof, may constitute “forward-looking information” within the meaning of Canadian securities legislation and “forward looking statements” within the meaning of US securities legislation “(selectively “forward-statements”). Forward-looking statements are frequently, but not always, identified by words such as “expects,” “anticipates,” “believes,” “intends,” “estimates,” “potential,” “possible,” “projects,” “plans,” and similar expressions. Such statements, based as they are on the current expectations of management, inherently involve numerous important risks, uncertainties and assumptions, known and unknown, many of which are beyond the Company’s control. Such risks factors include but are not limited to: business risks, market risks, and risks associated with micro-cap companies. Consequently, actual future results and events may differ materially from the anticipated results and events expressed in the forward-looking statements. The Company believes that expectations represented by forward-looking statements are reasonable, yet there can be no assurance that such expectations will prove to be correct. The reader should not place undue reliance, if any, on any forward-looking statements included in this presentation. These forward-looking statements speak only as of the date made, and the Company is under no obligation and disavows any intention to update publicly or revise such statements as a result of any new information, future event, circumstances or otherwise, unless required by applicable legislation or regulation.

# INVESTMENT HIGHLIGHTS

- **Enterprise SaaS Company** designing and manufacturing **AI drones**
- Selling to fastest growing sectors- **Defense, Agriculture, and Commercial** sectors
- Growing a US **Drone as a Service** business for convenient Uber-like, pay per use
- **Growth by Acquisition** adding to tech solutions and customers, revenue accretive
- **Favorable Capital Structure**- 60% Founder and management team owned & 90% of debt held by friends and family

\*Source: Industry data, Skyquest & Straits Research

NASDAQ: **ZENA**



# GLOBAL DRONE MARKET

**Commercial drone market growing from \$8.8B in 2022, expected to reach \$82.5B by 2032\***

**Military drones growing from \$14B in 2023, expected to reach \$47B in 2032\***

## Industry Drivers

- ✓ FAA/other aviation authorities- regulation more favorable to industry growth
- ✓ Tech innovation- drone batteries, lighter fuselage, AI and quantum
- ✓ US and other government policy shifts banning Chinese drones/parts that currently dominate the industry

## GROWTH, COMMERCIAL VERTICALS

**25-30%**  
Agriculture/Precision Farming

**20-25%**  
Infrastructure & Construction

**15-20%**  
Logistics & Delivery

**15-20%**  
Media & Entertainment

**10-15%**  
Security & Surveillance

**5-10%**  
Environmental Monitoring/Mgmt.

## Geographic Breakdown

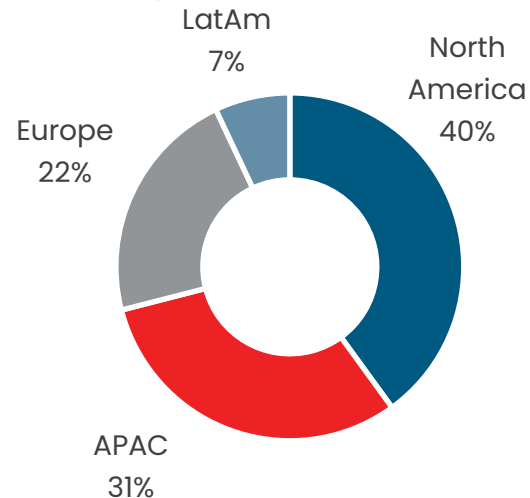

## Commercial Drone Market Size (USD\$)\*

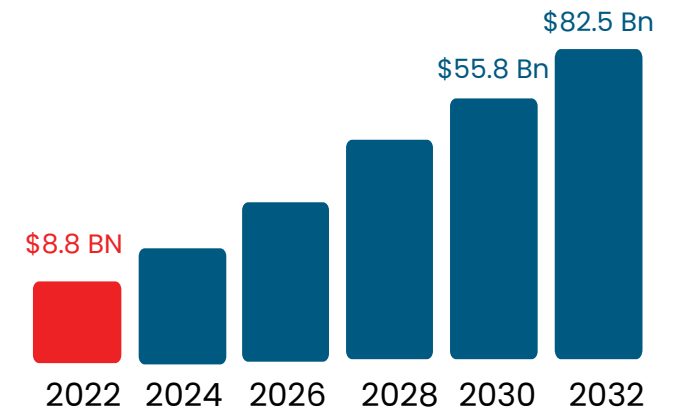



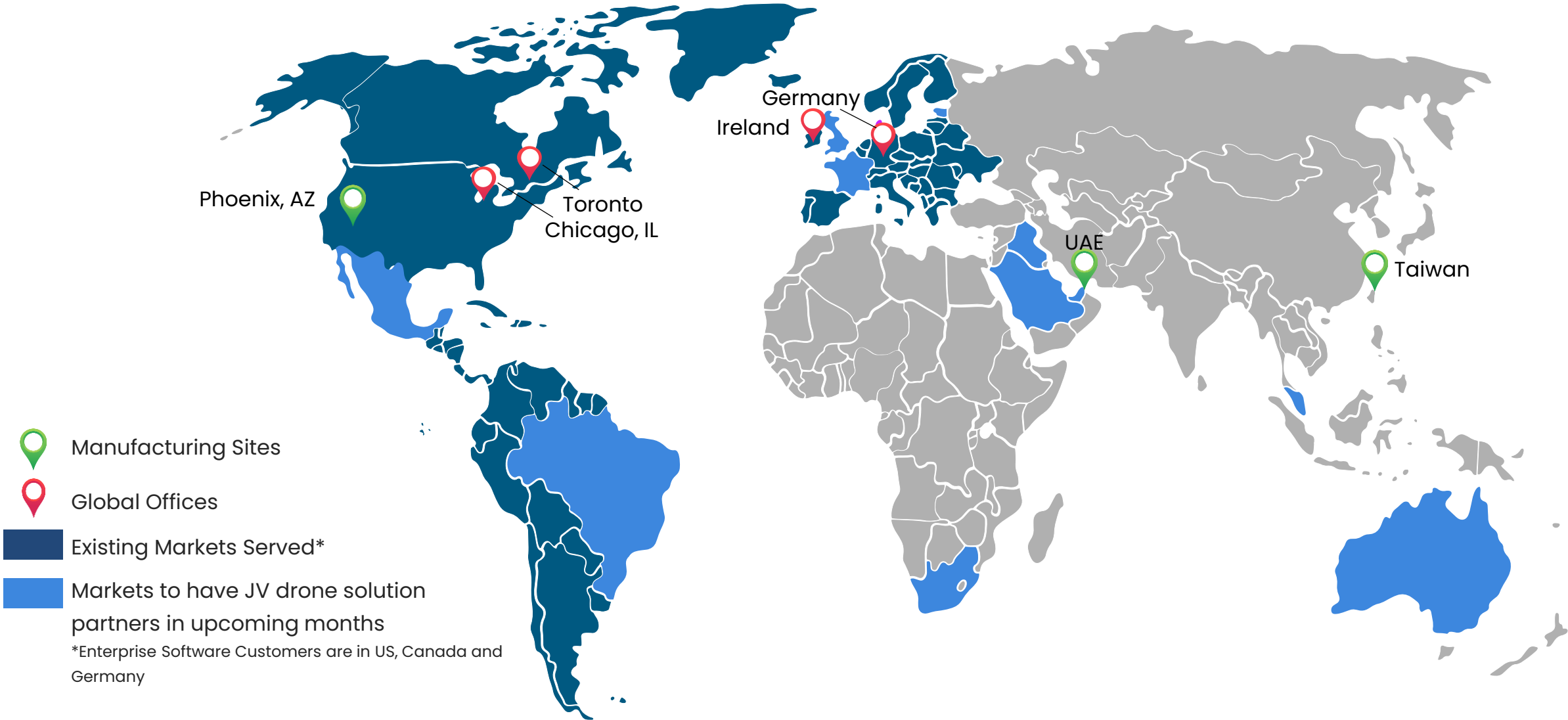

Source Industry Drivers/Sector size- Drone Life.com report on where the industry will grow the fastest by 2030- at 22/09/06, Military Drone market from Fortune Business Insights Research

\*Sources: Skyquest and Straights Research

# GEOGRAPHIC PRESENCE AND GROWTH



-  Manufacturing Sites
-  Global Offices
-  Existing Markets Served\*

 Markets to have JV drone solution partners in upcoming months

\*Enterprise Software Customers are in US, Canada and Germany

# COMPANY MILESTONES

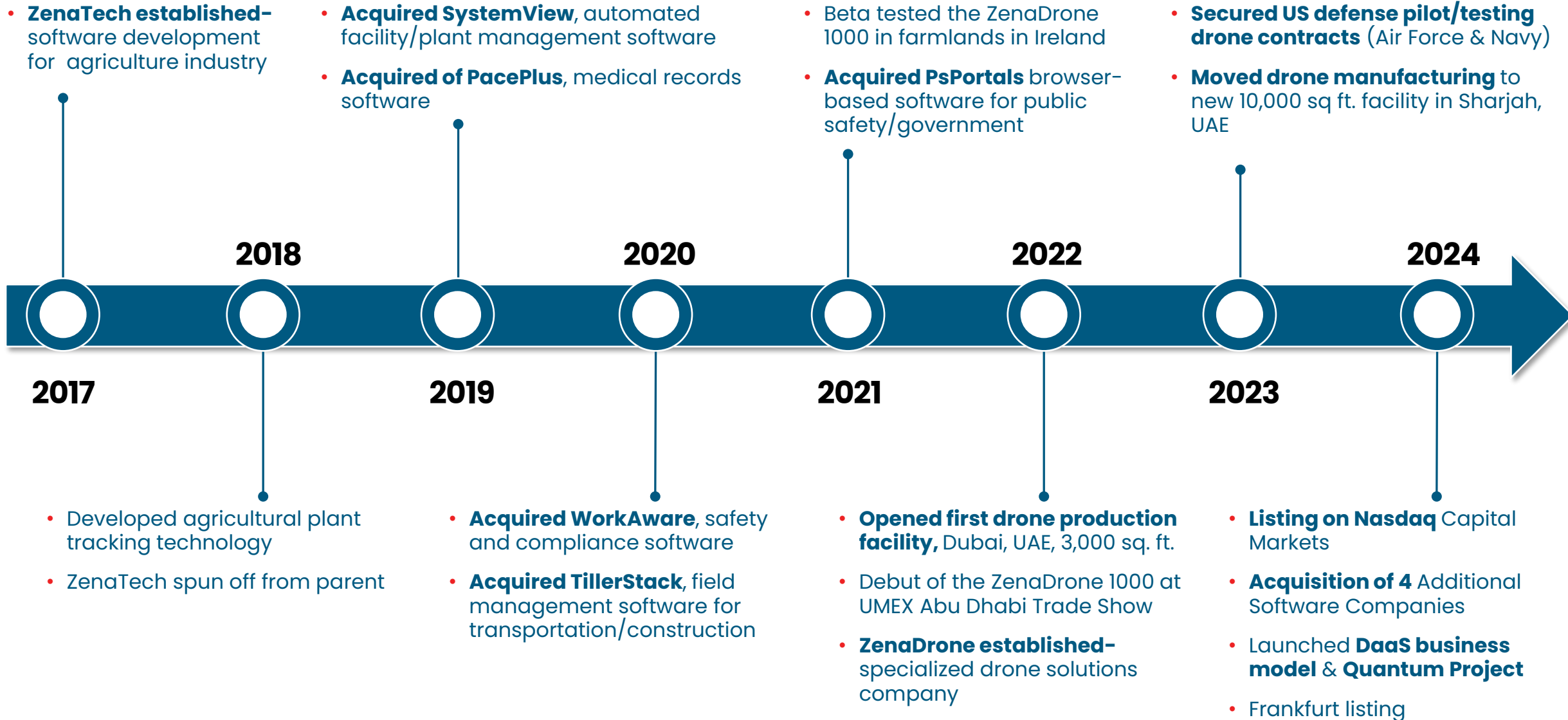

# OUR OFFERINGS

## DRONE TECHNOLOGY SOLUTIONS

ZENADRONES 1000

ZENADRONES IQ



## DRONE as a SERVICE MODEL (DaaS)

## ENTERPRISE SOFTWARE SOLUTIONS

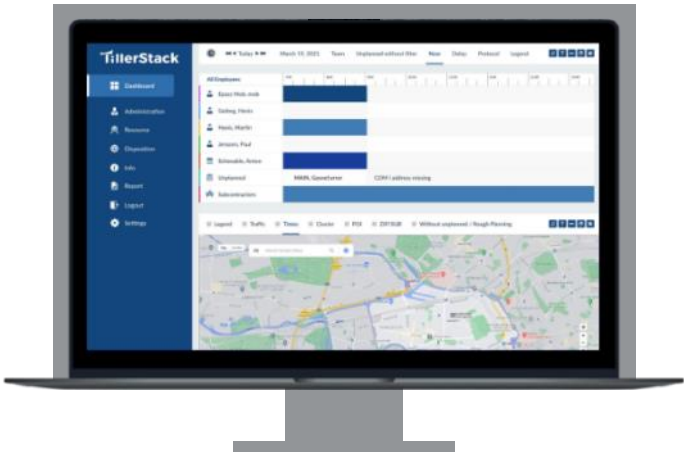

WorkAware

TillerStack

SystemView

PacePlus

PsPortals

ZigVoice

Jadian

DeskFlex

InterlinkOne

Interactive Systems



7 X 12 feet



10X10 to 20X20 inch

## ZenaDrone 1000

**Stable Flight, Exceptional Maneuverability, Advanced Scanning, Multiple Attachments, and Heavy-lift Capabilities**

**Sells for: \$100-250K plus software**

## ZenaDrone IQ Series

**Small Footprint, Designed for Indoor Use and Obstacle Avoidance, with Hover Stability, Auto Charging and Scanner/Sensing Capabilities**

**Sells for: \$1-4K plus software**



## AGRICULTURE

ZenaDrone 1000 has been piloted to help farmers cultivate higher yields, reduce labour and expenses utilizing plant tracking and Smart Farming solutions. Under development:

- Benchmark growth, scouting disease
- Fertilizer and Pesticide Spraying
- Crop and Fruit Farm Imaging
- Irrigation and Soil Management



## DEFENSE AND GOVERNMENT

ZenaDrone products have been used in paid pilots by US Air Force and US Navy for critical medical supply delivery in field operations, and for sub-zero climate deliveries. Others targeted:

- Search and rescue, disaster response and humanitarian aid
- Crowd monitoring and border patrol
- Operations inspection, intelligence gathering and security
- Firefighting and water spraying



## WAREHOUSE AND LOGISTICS

ZenaDrone IQ Nano indoor drone currently being used in a paid pilot to automate inventory management via bar code scanning inside a multinational auto parts customer warehouse. Others targeted:

- Warehouse security and surveillance
- Aisle and safety inspections
- Picking, packing and parcel sorting
- Warehouse mapping



# FUTURE CUSTOMERS-DRONES

## OIL AND GAS

- Pipe, flare stack and chimney inspection
- Offshore platform monitoring
- Site surveying and mapping
- Safety, compliance and environmental monitoring
- Security of sites and asset management



## MINING AND CONSTRUCTION

- Monitoring and security of indoor and outdoor assets
- Safety and compliance inspections
- Automation of processes, paperwork data collection and analysis/AI
- Terrain mapping and site survey applications



## FORESTRY AND ENVIRONMENTAL

- Land surveys, animal tracking/migration
- Forest management, seed planting for reforestation
- Environmental planning and compliance
- Forest fire and emergency management



## RENEWABLE ENERGY

- Data collection, monitoring the health of assets
- Power line/wind turbine/solar inspections and tracking
- Emergency management
- Safety and security applications



# ZENATECH – REVENUE MODELS

## Enterprise Software Q3 YTD sales revenue, \$2 M

- SaaS – Annual license
- Support & Maintenance
- Software Development
- Training

**Sales Channels:** Digital Marketing, Sales & Customer Support

**NASDAQ:** ZENA

## Drone Customers at paid trials stage

- Drone hardware and accessory sales
- Drone management fee
- Drone software license
- Drone warranty (hardware and accessory replacement)
- Hardware/software customization
- Software maintenance and support

**Sales Channels:** Direct Sales, JV Distribution Partners

## Drone as a Service (DaaS) launched November 2024

- DaaS annual subscription membership and per fee use
- Drone management fee
- Hardware/software application customization

**Sales Channels:** Digital Marketing, Direct Sales, JV Distribution Partners and resellers

# HIGHLIGHTED SOFTWARE CUSTOMERS

## ZIGVOICE

## TillerStack

## PsPortals



## SystemView

## PACE+

## WorkAware



# DRONE MANUFACTURING

- **UAE production facility** established 2022, expanded to 10,000 sq feet in 2023
- Produced and tested 14 successive prototypes of ZenaDrone 1000, #15 is Production model
- Production capability of 10-15 ZenaDrone 1000 models per mon. starting in Q1 2025
- Production capability of 25+ IQ Nano/IQ series drones for inventory management, other applications
- **Arizona production facility**, currently aerial testing site & R&D center, will manufacture drones for US Military
- **Spider Vision Sensors in Taiwan** established Nov. 2024, US military compliant cameras in Q1, plus other components/supply chain for our drones

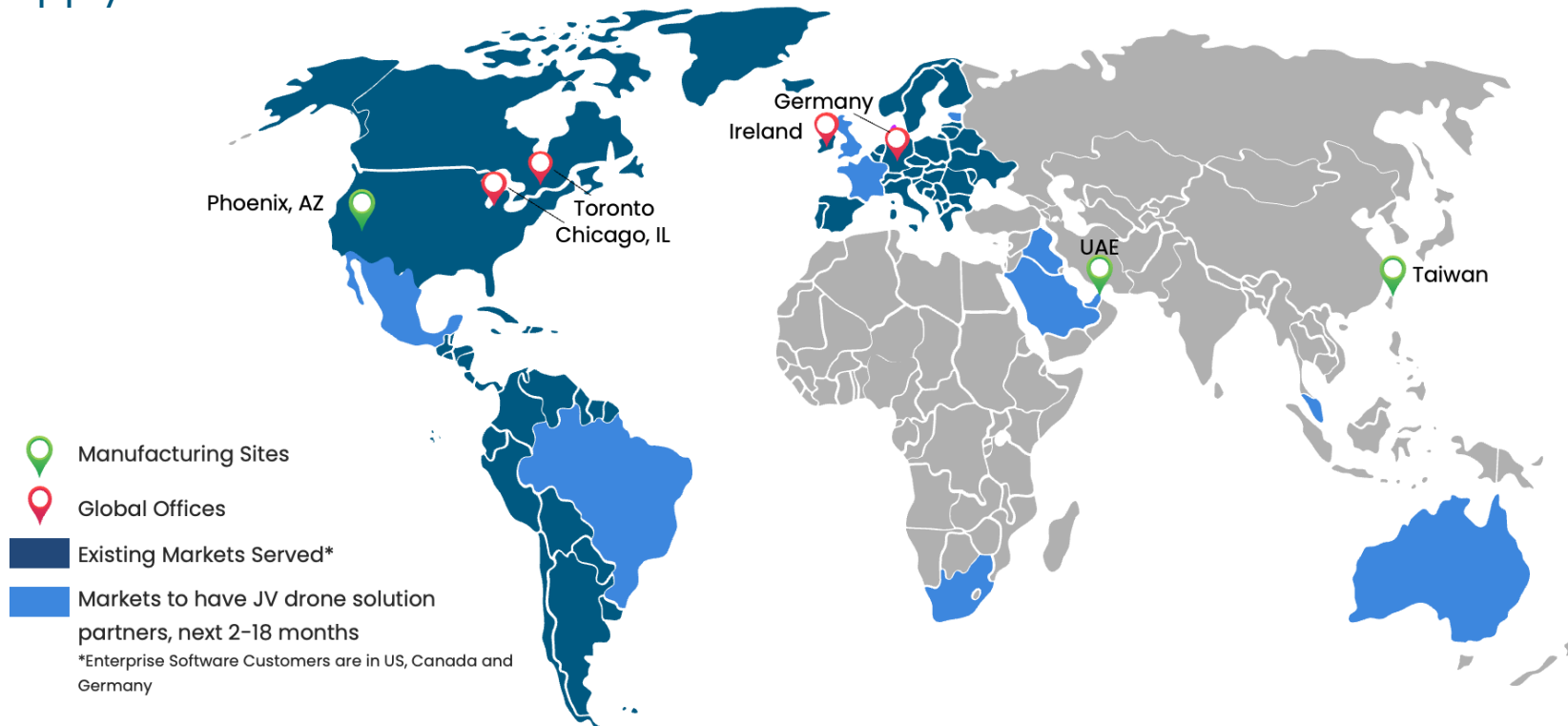

## 2 Patents for Drone Design

- ZenaDrone 1000

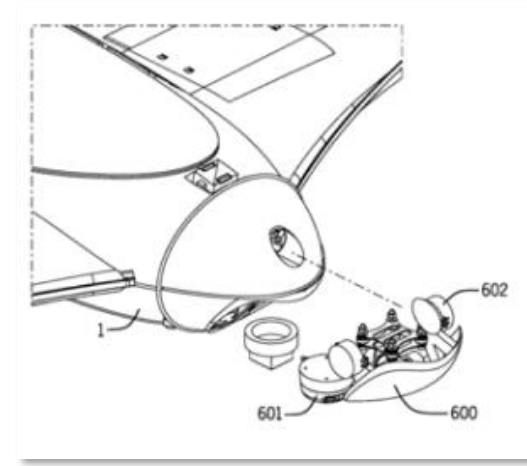
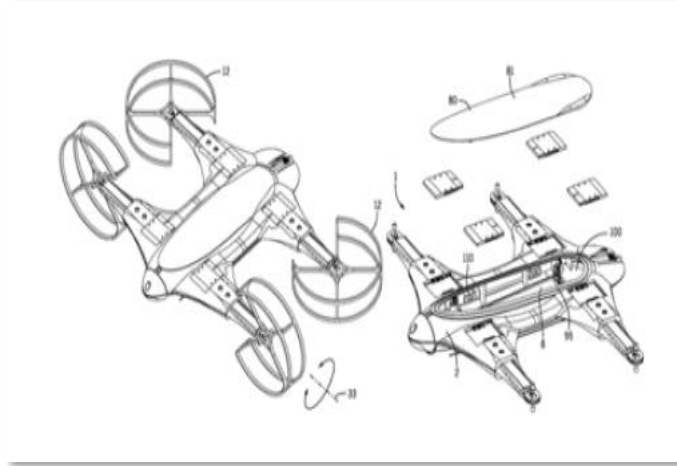

## 2 Patents for Drone Attachments including:

- Drone with extendable and rotatable wings and multiple accessories securing panel
- Charging/Re-Charging Drone Assembly Systems and Apparatus Pad

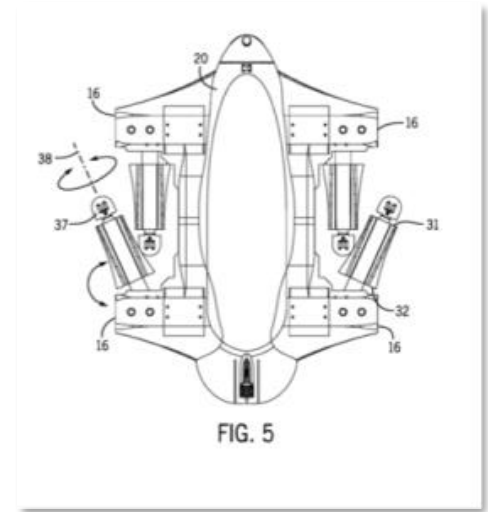
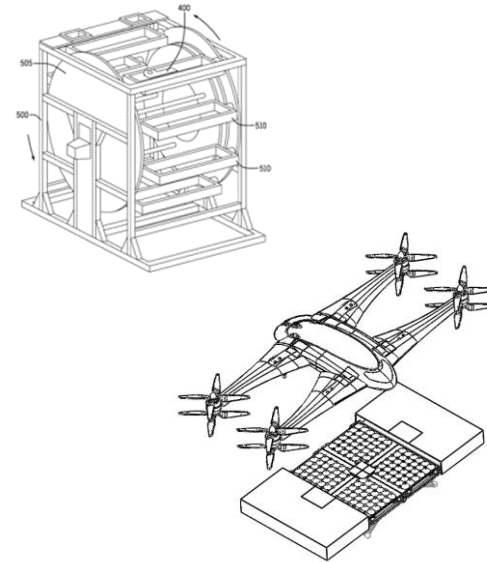

# EXECUTIVE LEADERSHIP TEAM



## SHAUN PASSLEY, PHD | CHAIRMAN & CHIEF EXECUTIVE OFFICER

- Over 25 years of expertise in the software industry, more than 10 years leading public companies.
- Serves as CEO and Chairman of the Board of ZenaTech
- Holds a PhD in Business Management and a master's in business administration from Benedictine University. Also has four master's degrees; a Master of Law from Northwestern University, a Master of Science in Information Technology from DePaul University, and a Master of Science in Product Design from Northwestern University
- A distinguished figure in the tech and business world



## JAMES SHERMAN, CPA | CHIEF FINANCIAL OFFICER

- Has worked for 30 years as a Certified Public Accountant (CPA). Graduated with Honors from Northern Illinois University.
- Started career at a Fortune 500 telecommunications firm, rising through the ranks of finance roles
- Served as Treasurer for a \$3.5 billion division of Sprint Corporation, led a \$50 million cost-saving initiative
- CFO of a \$90 million national transportation and distribution company, led a turnaround from potential bankruptcy to ready for sale
- Served as CFO for Carry Corporation, a \$250 million division of Mitsubishi Corporation



## SAJJAD ASIF | CHIEF TECHNOLOGY OFFICER

- 18 years of professional experience and expertise in software and drone technologies.
- Holds Master of Science in Software Engineering degree from Blekinge Tekniska Högskola (BTH) in Sweden, an MBA from AIOU in Pakistan, and a BS - Computer Science from PUCIT in Pakistan
- Held leadership positions with the ZenaTech group of companies, now focused on ZenaDrone solutions and integration
- Held CTO and other leadership and technical roles for multiple European technology firms



## LINDA MONTGOMERY | VP CORPORATE DEVELOPMENT

- Over 20 years in technology industry globally leading investor relations, business development and in CMO roles
- Has led investor relations for various companies and for six IPOs including Zenos Group (acquired by Open Text), Treasury Metals, Lydian International, and Kensington Capital Partners
- Previously national marketing leader roles at KPMG and Telesat Canada, General Manager for a Venture Builder Agency
- Two business degrees from the University of Winnipeg and the University of Manitoba, holds an Investor Relations Accreditation (CPIR) is from the Ivey School of Business at Western University and the Canadian Investor Relations Institute



## SIMON HENRY | VP OF BUSINESS DEVELOPMENT, EMEA

- Over 20 years of sales leadership and client service management background in various industries, including the Bank of Ireland
- Leads ZenaTech's ZenaDrone company pilot programs and customer/partner growth in Ireland and EMEA regions.
- Previously roles in business development, client management and sales for companies including a global payroll outsourcing company, a fleet management company, and a business gift retailer achieving sales objectives for business clients.
- Degree in Business Studies from Dublin Business School (Honors) and a Masters Degree in Sales Management from UCD Michael Smurfit Graduate Business



## PHILANDER FRANKLIN | VP OF BUSINESS DEVELOPMENT, NA

- Over 25 years of professional experience in sales and operations leadership
- Has worked in various capacities globally for ZenaTech's portfolio of companies leading customer support, operations management, partnerships and regulatory affairs
- Previously was a sales leader in the healthcare insurance industry for Blue Cross Blue Shield provider, GoHealth, where he achieved top awards for his sales and revenue achievements
- Led the growth of a retailer in Chicago, expanding to 7 stores in two years and managing over 100 employees.



# COMPETITIVE ANALYSIS

Company	Application			Size/Range			Platform		Functionality
	Military/Defense	Commercial	Public Safety	Small Indoor	Small Outdoor	Medium Outdoor	Fixed Wing	Rotary	AI
	✓	✓	✓	✓	✓	✓		✓	✓
Red Cat	✓	✓	✓		✓	✓	✓	✓	✓
Draganfly	✓	✓	✓		✓	✓		✓	✓
AgEagle	✓	✓	✓		✓	✓	✓		✓
Ondas Holdings	✓	✓	✓			✓		✓	✓
AeroVironment	✓	✓	✓		✓	✓	✓	✓	✓
Skydio	✓	✓	✓		✓	✓	✓	✓	✓

# REGULATORY APPROVAL STATUS

**Approval Granted**



**Federal Aviation Administration (FAA)**



**Dubai Civil Aviation Authority and Ministry of Defence**

Country	Regulatory Body	Approval Status	Approval time
	Canadian Transport Authority	Not Applied	8-9 weeks
	EASA-European Union Aviation Safety Agency	Not Applied	8-10 weeks
	Irish Aviation Authority	In-progress	12-20 weeks

# CAPITALIZATION SUMMARY

Stock Symbol	NASDAQ: ZENA FSE: 49Q
Stock Price (As of 01/17/25)	\$6.12
Basic Shares Outstanding	17,308,328
Market Capitalization	\$108M
Warrants Outstanding	355,551
Fully Diluted Shares	17,663,879
At least 60% of shares owned by Founder, Insiders	



# INVESTMENT HIGHLIGHTS

- **Enterprise SaaS Company** designing and manufacturing **AI drones**
- Selling to fastest growing sectors- **Defense, Agriculture, and Commercial** sectors
- Growing a US **Drone as a Service** business for convenient Uber-like pay per use
- **Growth by Acquisition** adding to our solutions and customers, revenue accretive
- **Favorable Capital Structure**- 60% Founder and management team owned & 90% of debt held by friends and family

\*Source: Industry data, Skyquest & Straits Research

NASDAQ: **ZENA**



# ZENA TECH

Contact Information:

**Linda Montgomery**

VP, Corporate Development

[investors@zenatech.com](mailto:investors@zenatech.com)

**Mike Mason**

CoreIR



NASDAQ: ZENA | FSE: 49Q